



ALPINE

RESORT

2024 WEDDINGS



ALPINE

RESORT

The Alpine Resort History...

Brothers Paul and John Bertschinger first opened The Alpine Lodge in 1922. It was noted to be the first tourist destination in Egg Harbor, and at the time, one of the largest resorts on the peninsula.

In 1924, the Bertschingers purchased more property adjacent to the resort and named it Alpine Point Beach. Intentions were to build a dock for visiting yachts as well as cottages for summer homes. The Door County Advocate boasted that the cottages would include modern conveniences. Electricity and running water were fueled by the resort's power plant.

The Alpine Resort operated under the classic American plan. They offered three meals a day in the lodge's dining rooms. Guests also had the option of rooms in the lodge or a number of small cabins. Guests would travel by steamship to Sturgeon Bay and make their way up the peninsula. Later, Door County's roads improved; some were chauffeured from their homes in Chicago. Daily activities were included for adults and children which included nightly dances that were held in the main lodge.

The Alpine Resort offered 36 holes of golf at its peak. You could ride an electric tram for a quarter from the lower holes to the top of a steep bluff that offered stunning views of Green Bay, and a challenging shot on a par 3. Later some of the course was sold and only 18 holes were available for play.



Let the Alpine waterfront
be the perfect location for
your wedding or event!



Waterfront Tent

DAY OF EVENT INCLUSIONS:

- Exclusive use of the 4000 square foot sail cloth tent
- Full clear side panels for the tent if needed
- Italian Lighting on dimmers
- Full wood flooring throughout the tent



Facility Inclusions



- Round 66" tables for guests seating (up to 10 per table) Maximum seating for 200
- Additional accent tables available in various sizes and heights
- Glassware for cocktail hour and dinner, plastic provided after dinner service
- Full place setting for dinner
- Bathroom facilities adjacent to the tent
- Detailed full layouts for tent space
- Crossback wood chairs available

Additional Information

- All decorations must be freestanding. Decorations may not be hung from light fixtures, nor attached to the tent or Alpine Resort buildings
- Rice, confetti, birdseed, flower petals, balloons, glitter, fog machines, pyrotechnics, sparklers, fireworks, and bubble machines are not permitted inside or outside of the facilities
- Enclosed flame candles or LED are permitted inside and outside
- All decorations must be pre-approved by the Alpine Resort
- 200 white garden folding ceremony chairs for an additional fee
- Smoking is only permitted in designated areas
- All desserts other than wedding cake will be provided by Alpine
- Heaters in tent available for an additional fee
- All property belonging to the client, guests and vendors shall be delivered and removed the day of the contracted event
- All amplified music and live bands must cease at 11:00pm due to local ordinances
- Clients and guests must be out of the tent no later than 11:15pm
- Additional fees will apply for all guests staying past the end time
- All vendors must be out by 11:59pm
- Client expressly grants Alpine Resort permission to take photographs of the event and use them for marketing purposes
- Any guest room delivery must be communicated 2 weeks prior to event date. There is a \$2.00 per room charge for all gift bag deliveries. All bags must be the same for each cabin



Financial Information

- Pricing for 2024 Waterfront Tent on weekends is \$14,000 with a food and beverage minimum of \$16,000
- 22% is added to all food and beverage charges
- The total bill which includes food, beverage, service charge, room rental and any additional charges are subject to a WI and local tax of 5.5%
- Initial payment: In order to lock in a date, a contract will be provided to the client which needs to be signed and returned with the deposit, which is the cost of the venue rental fee



After a date is contracted, the below will take place:

1. All available cabins will be blocked for your group. A deposit of 50% will be due with each guest's booking. The client will be responsible for payments of any cabins that are not booked by guests
2. Your Alpine representative will reach out to get a tasting date in place

You can bring up to a maximum of 6 total people to your tasting

3 salads, 3 entrees, along with 5 sides (veggie and starch)
3. Three months prior to the event date, your preliminary food (for dinner, you will be allowed to choose 3 total entrees including a vegetarian meal) and beverage decisions are due to the Alpine along with a 50% payment that will be applied to the estimated Banquet Event Order
4. Twenty-one days prior to your event date, the balance is required based on your Banquet Event Order

A credit card will be placed on file for any outstanding charges or incidentals to be collected after full payment

All payments are due by check or money order



Lodging Information

- During your stay, you'll have access to complimentary wifi, self-service laundry facility, premier golf and on-site bar and restaurant
- Each charming 1 to 3 bedroom cottage and clubhouse rooms is newly modernized with updated cozy features – including fully renovated baths, climate control, service bar, plus a porch with cedar plank floors. Select cottages include dual porches and waterfront views
- A room block of 15 or 29 cottages for 3 nights is required and offered for Saturday events. Once the contract and retainer are in place, the cabin block will be open for couples to assign lodging for the guests or have guest call in to book directly. All deposits must be in place 120 days prior to the event. Any cabins without deposits will be open to the general public. In the event that a group does not fill all 29 cottages, there will be security on-site with quiet hours starting at 11:00pm due to guests outside of the event lodging with us





ACCOMMODATIONS

1 BEDROOM/1 BATH (Nightly Rate)

Alabama	383 Sq Ft	\$345
Idaho	383 Sq Ft	\$345
Iowa	404 Sq Ft	\$345
Kansas	383 Sq Ft	\$345
Michigan	383 Sq Ft	\$345
Minnesota	383 Sq Ft	\$345
Mississippi 	383 Sq Ft	\$345
Nevada	383 Sq Ft	\$345
Ohio	380 Sq Ft	\$345
Oklahoma	383 Sq Ft	\$345
Virginia	383 Sq Ft	\$345

2 BEDROOM/1 BATH (Nightly Rate)

Arizona	510 Sq Ft	\$395
Florida	510 Sq Ft	\$395
Indiana	551 Sq Ft	\$395
Maine	510 Sq Ft	\$395
Missouri	551 Sq Ft	\$395
New York	661 Sq Ft	\$395
Tennessee	510 Sq Ft	\$395

3 BEDROOM/1 BATH (Nightly Rate)

California	596 Sq Ft	\$445
Illinois	596 Sq Ft	\$445
Nebraska	596 Sq Ft	\$445
Oregon	641 Sq Ft	\$445
Pennsylvania	510 Sq Ft	\$445
Texas	641 Sq Ft	\$445
Wisconsin	596 Sq Ft	\$445

2 BEDROOM/2 BATH (Nightly Rate)

Arkansas 	661 Sq Ft	\$395
Kentucky	661 Sq Ft	\$395
Maryland	900 Sq Ft	\$395
Louisiana	900 Sq Ft	\$395

CLUBHOUSE ROOMS

1 BEDROOM/1 BATH (Nightly Rate)

Suite 1	236 Sq Ft	\$340
Suite 2	157 Sq Ft	\$340
Suite 3	254 Sq Ft	\$340
Suite 4	241 Sq Ft	\$340
Suite 5	282 Sq Ft	\$340



Subject to availability. Prices accurate as of October 2022.

www.alpineresort.com
 920.868.3000
 7715 Alpine Road
 Egg Harbor, WI 54209

ALPINE RESORT



Alpine Lane

First Lane

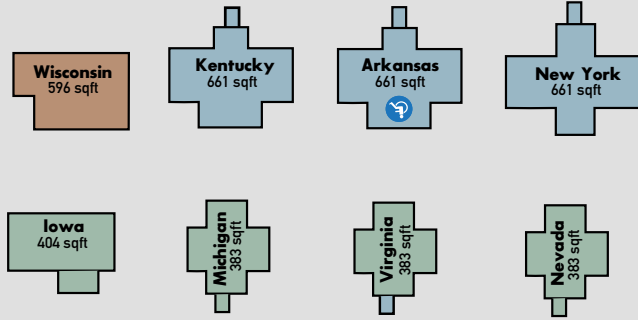

Second Lane

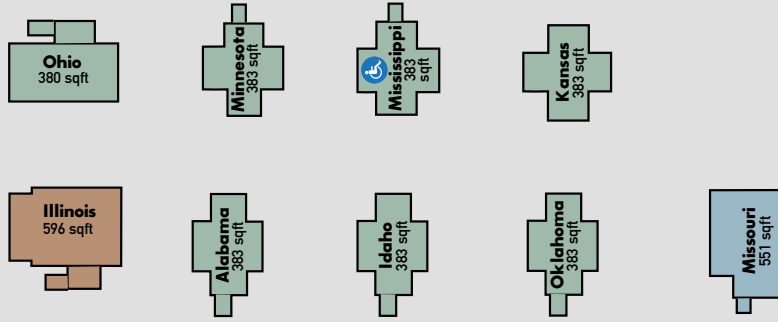

Third Lane

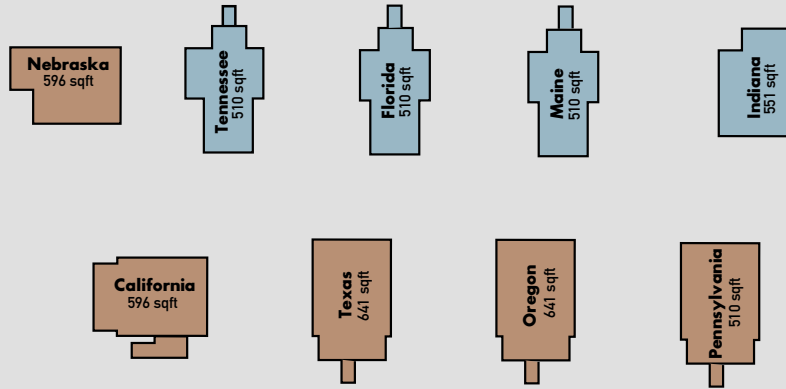

Fourth Lane

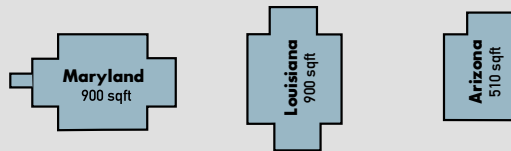

- 1 Bedroom
- 2 Bedroom
- 3 Bedroom

GOLF COURSE CLUB ROOMS
 ← 5 Suites with King Beds

Alpine Road

MAIN ENTRANCE

Horseshoe Bay Road